

INSTALLATION GUIDE

AMP RESEARCH Power Step

MADE IN USA

APPLICATION	LENGTH	MODEL YR	PART #
Ford F150 SuperCab *	72"	2004-2008	75105-01A
Ford F150 SuperCrew	79"	2004-2008	75105-01A

***Modification required to running board assembly. See Item 1 on page 3.**



INSTALLATION TIME

3:00 hrs

SKILL LEVEL

1

2

3

4

4= Experienced

- TOOLS REQUIRED**
- Safety goggles
 - Measuring tape
 - Flat blade screwdriver
 - Phillips head screwdriver
 - 8 mm socket
 - 10 mm socket
 - 13 mm socket
 - 13 mm end wrench
 - Ratchet wrench and extension
 - Wire crimpers
 - Wire stripper
 - Corrosion inhibitor
 - 3/16" hex key wrench (allen wrench)
 - 4mm hex key wrench (allen wrench)
 - Electrical tape
 - Weather proof caulking (silicone sealer)

AMP RESEARCH TECH SUPPORT 1-888-983-2204 (Press 2) Monday - Friday, 6:00 AM - 5:00 PM PST

Designed and manufactured by AMP Research®. Patent Number 6,830,257; 6,641,158; 6,834,875; 6,938,909; 6,942,233; 7,007,961; 7,055,839; 7,163,221; 7,367,574; 7,380,807; 7,398,985; 7,413,204; 7,487,986. Other US and Worldwide patents pending. Made in USA © 2010 AMP Research
5-year limited warranty. Professional installation is recommended.

INSTALLATION GUIDE

Attaching motor to linkage assembly

The motors must be attached to the linkage assemblies before continuing the installation process.

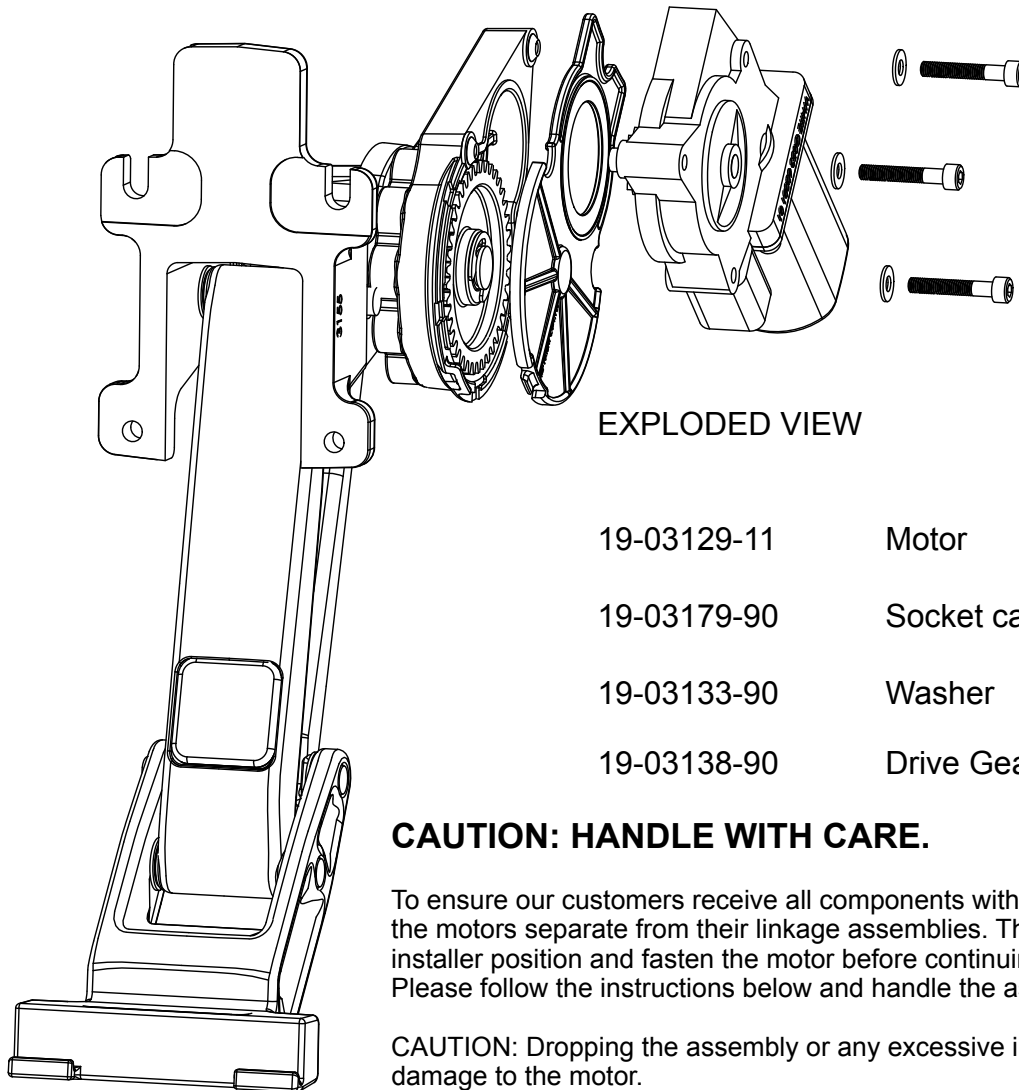

EXPLODED VIEW

19-03129-11	Motor
19-03179-90	Socket cap screw
19-03133-90	Washer
19-03138-90	Drive Gear Housing Cover

CAUTION: HANDLE WITH CARE.

To ensure our customers receive all components with full integrity, we pack the motors separate from their linkage assemblies. This requires that the installer position and fasten the motor before continuing with the install. Please follow the instructions below and handle the assembly carefully.

CAUTION: Dropping the assembly or any excessive impact **MAY** cause damage to the motor.

Instructions:

1. Position the gear cover in place as shown if not already in place.
2. Seat motor into position on the three mounting bosses. This may require an adjustment of the gear by moving the swing arms.
3. After seating into place, fasten the motor with the three motor mount screws with 4mm Hex Head. Tighten screws to 36 in-lbs (4N-m). **Do not over torque.**

AMP RESEARCH POWER STEP – FORD F150

Note: Some Applications require modification.

Application	Cut Length
Super Crew	79" (No Modification Required)
Super Cab	72" (Trim 7")

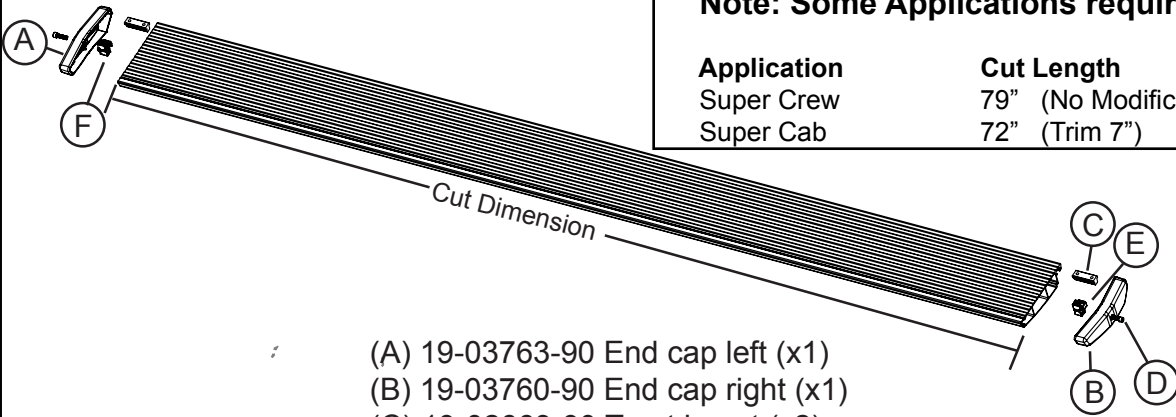

- (A) 19-03763-90 End cap left (x1)
- (B) 19-03760-90 End cap right (x1)
- (C) 19-02663-90 T-nut insert (x2)
- (D) 19-02802-90 Socket cap screw (x2)
- (E) 19-03761-90 End cap wedge right (x1)
- (F) 19-03764-90 End cap wedge left (x1)

1 x2

Running board assembly

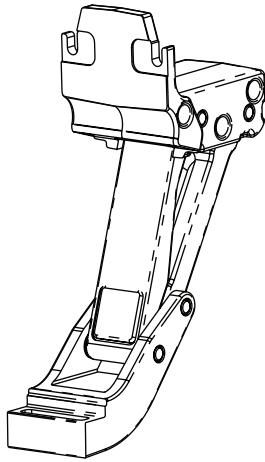

2 x2

10-03007-11
Idler linkage assembly

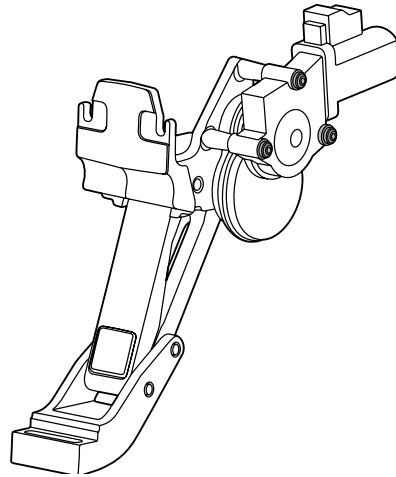

3 x2

10-03006-11
Motor linkage assembly

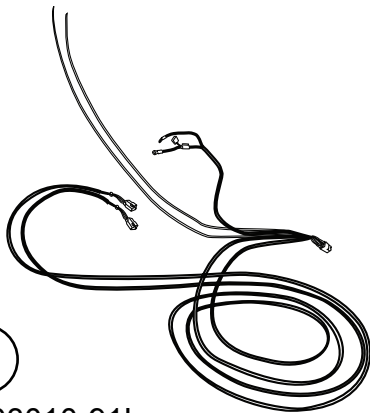

4

19-03010-91L
Wire harness

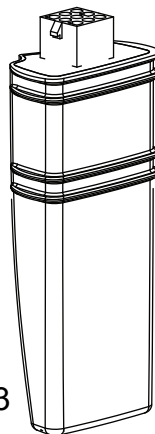

5

19-03297-93
Controller

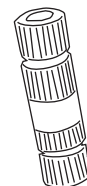

6 x4

19-03354-90
Posi-Tap™ (Red/Grey)

PARTS LIST AND
HARDWARE
IDENTIFICATION

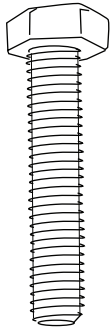

7 x8
19-02487-90
Hex bolt

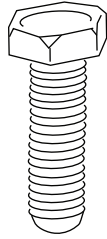

8 x9
19-02849-90
Hex Bolt

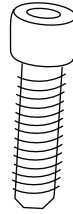

9 x8
19-02802-90
Socket cap screw

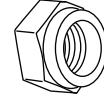

10
10-00115-60
Nylock Nut

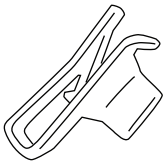

11 x8
19-02488-90
U-nut

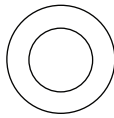

12 x8
16-03014-90
Washer Black

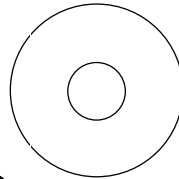

13
19-02389-90
Washer

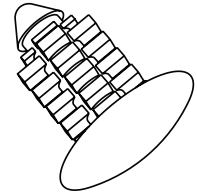

14 x2
19-03063-90
Rivet



15 x20
19-02805-90
Cable Ties 7"

16
16-03048-90
Bracket

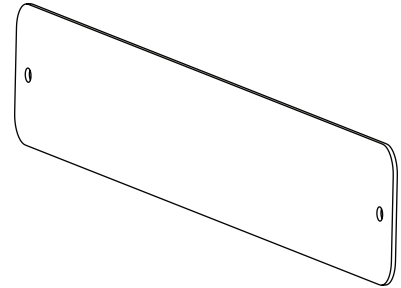
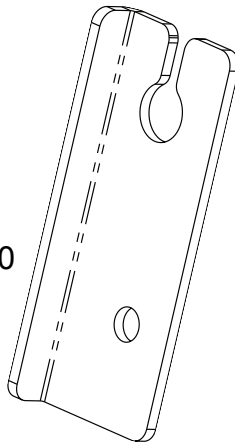

17
19-03049-90
Plug Shield

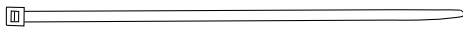

18 x2
19-03339-90
Cable Ties 11"

19 x4
19-03302-90
LED Lamp

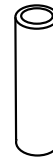
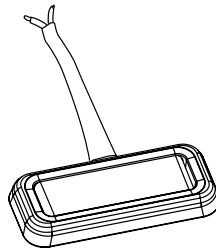

20 x8
19-02989-90
Butt Connector

Find wire harness cover on the frame under the driver's door. Remove both tree clips and remove wire cover.

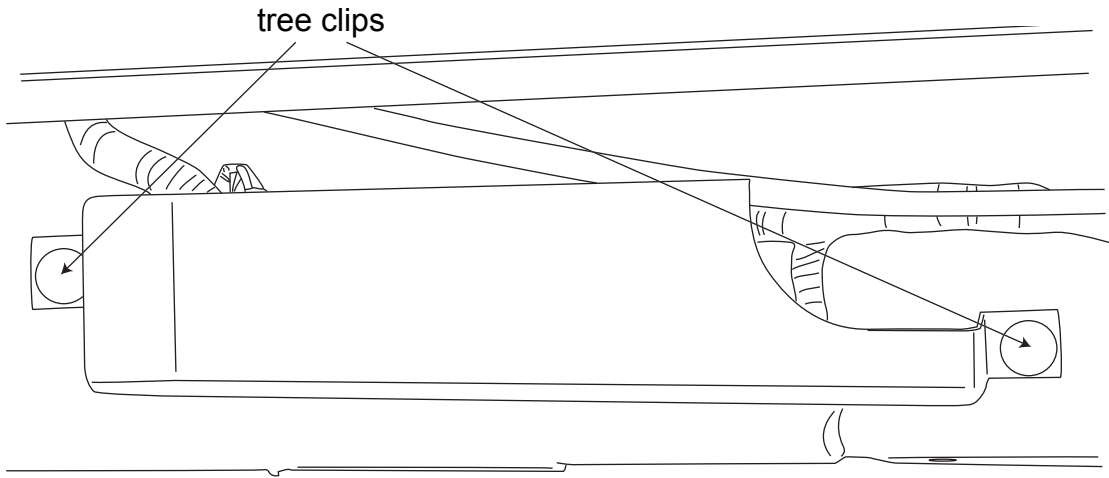

Bend new cover into position and attach with the large tree clips supplied with hardware.

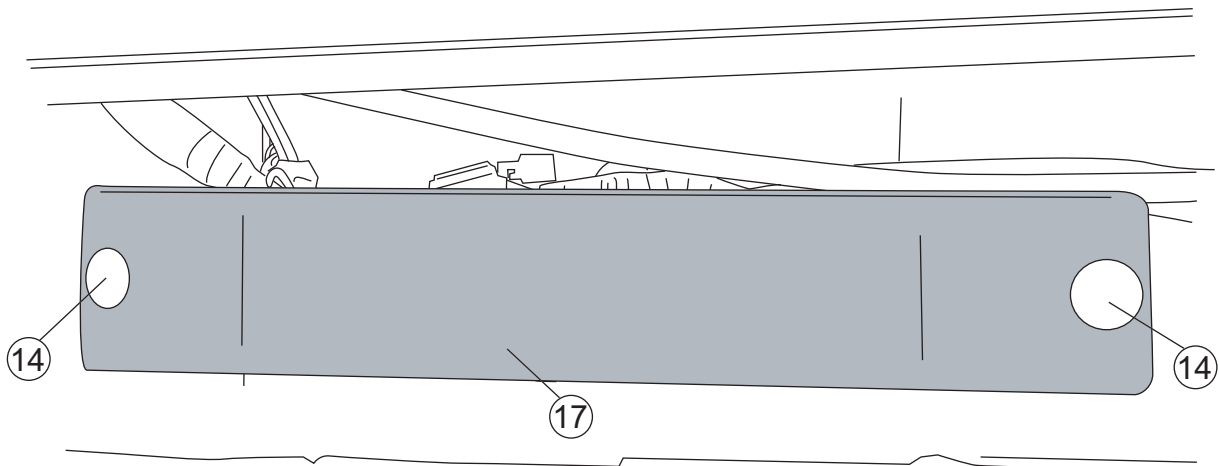

Mount brake cable bracket extension and then raise brake cable into position.

Note: First pull brake cable downward to create slack before raising into position.

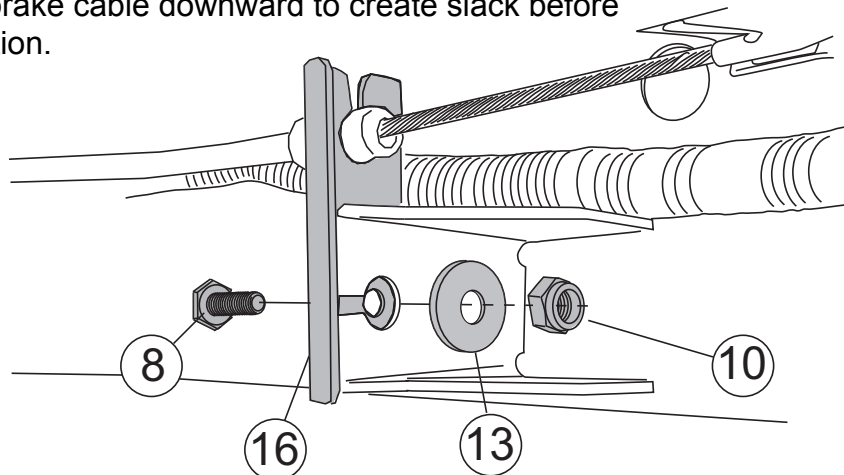

Locate mounting points; first and last set of holes on the inner sill.

Motor Linkage mounts toward the rear of the truck, with the exception of the passenger side of SuperCab. With the SuperCab, mount the motor linkage in front on the passenger side (covering the motor with supplied heat shielding).

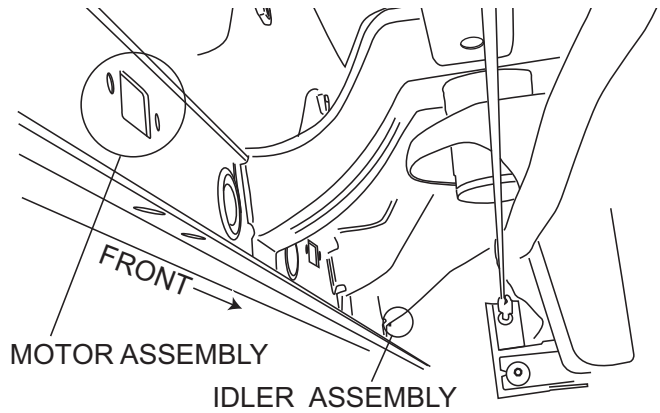

4

Drivers side pictured here.

Install J-clips and start bolts with washers installed.

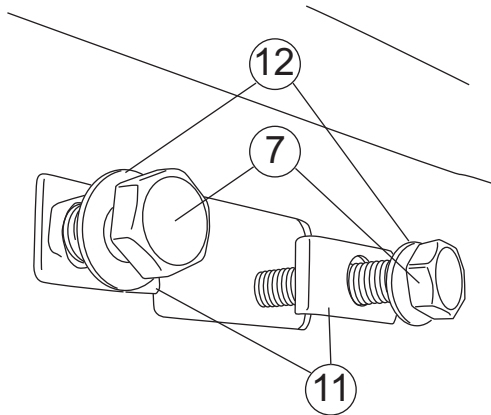

5

Remove fan shroud to allow for wire routing. Shroud will be reinstalled in a later step.



7

Mount idler assembly and motor assembly.

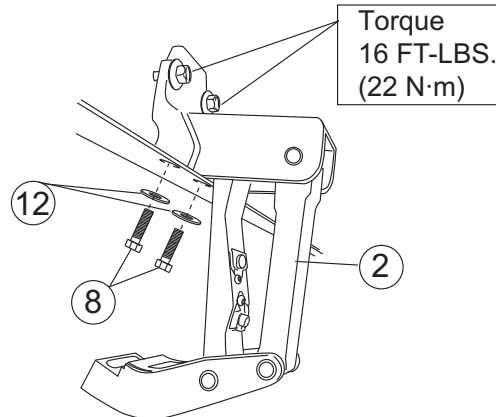

6

Note: Filing of sheet metal edge may be required if the sheet metal holes are misaligned.

Mount controller with the two 11" tie wraps to factory conduit. Route wire harness under core support and down toward controller. Attach harness to controller (make sure connector locking tabs fully engage).

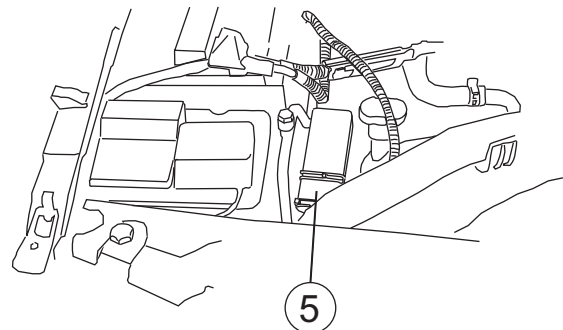

8

Secure harness with tie wraps.

Remove fuse.

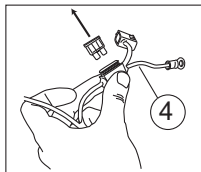

Connect red and black power leads to battery. Red lead goes to positive. Route shorter leg of harness down passenger-side wheel well.

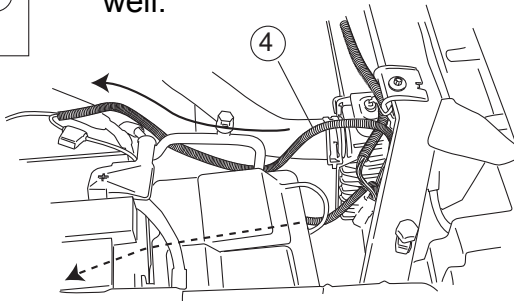

9

Route longer leg of harness across front and down under driver side. Secure harness with tie wraps and reinstall shroud.

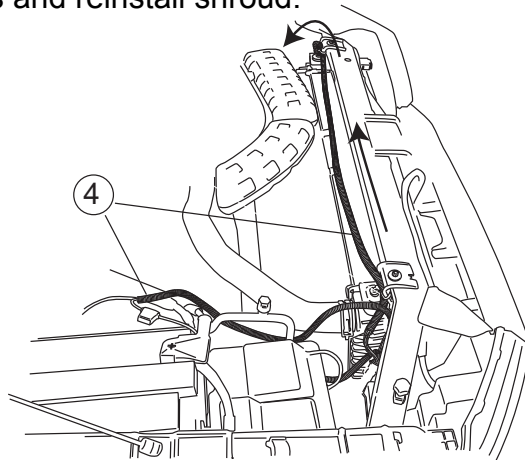

10

Route longer leg of harness down along driver-side wheel well and along frame of vehicle. Secure with tie wraps.

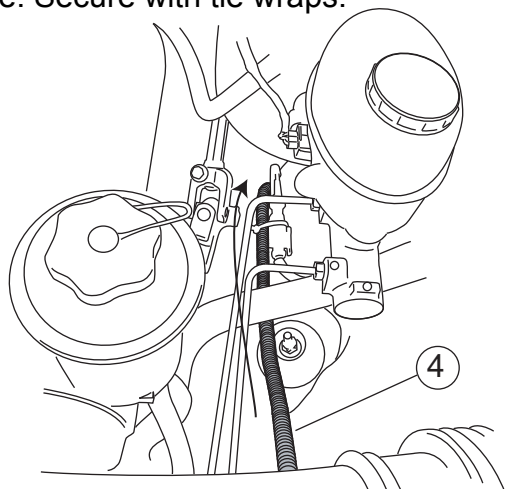

11

Puncture grommet and thread all four trigger wires up into the cabin of vehicle. The grommet is located on driver-side behind forward linkage assembly.

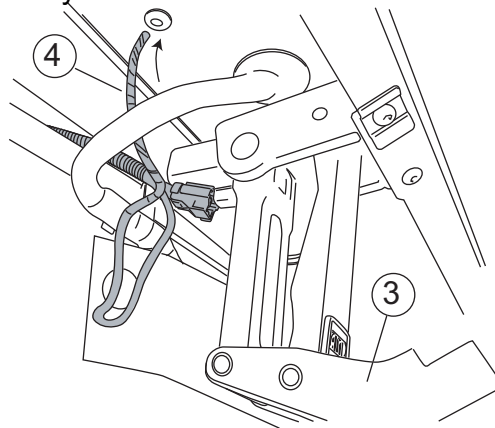

12

Remove drivers-door sill plate and pull back carpet to reveal trigger wires threaded through grommet.

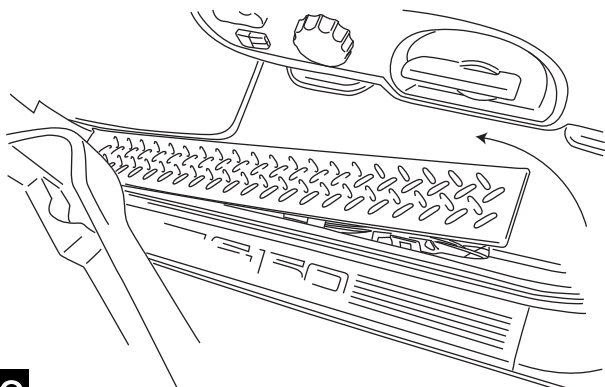

13

Pull wires from grommet and route back along factory wire harness to back door sill plate.

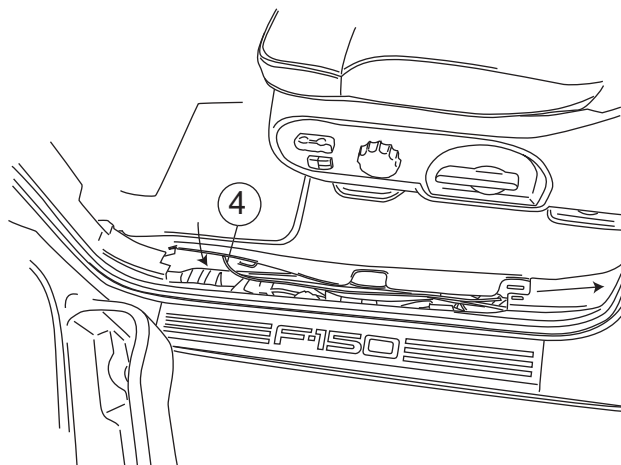

14

AMP RESEARCH POWER STEP – FORD F150

Remove rear door step plate and open wire bundle. Route trigger wires to rear door sill plate.

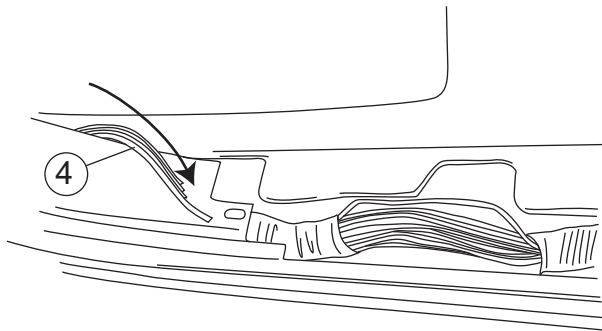

Locate the appropriate signal wires as noted below. Note: There may be up to five Black with Blue Stripe wires; use the one that looks unique (ie. different blue stripe... weight and shade).

	SuperCrew	SuperCab	Regular Cab
Driver Front	Black / Yellow	Black / Yellow	Black / Yellow
Pass. Front	Black / Pink	Black / Pink	Black / Pink
Driver Rear	Black / Blue		
Pass. Rear	Black / White		

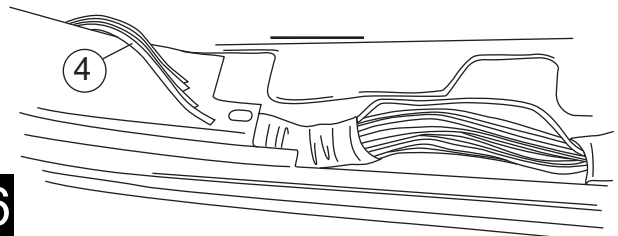

15

16

Using supplied Posi-Taps™, splice Power Step trigger wires into the corresponding door ajar wires. The SuperCrew (having 4 independent doors) is the only application that will use all four wires; tape off the two unused trigger wires on the SuperCab and Regular Cab.

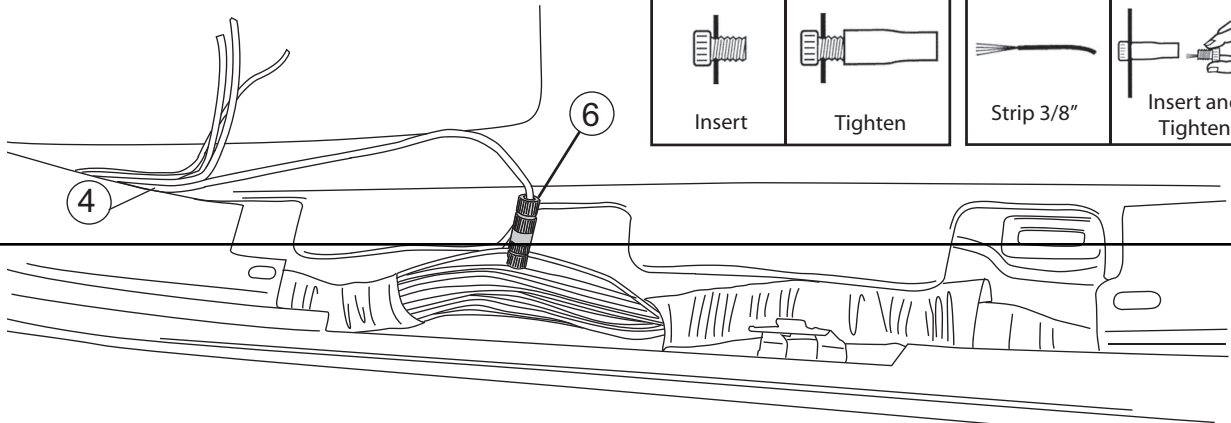

17

Attach step, sliding the mounting T-nut into position.

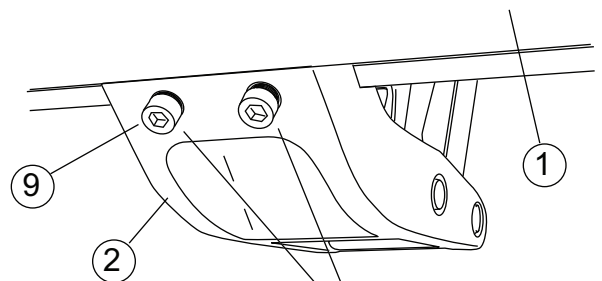
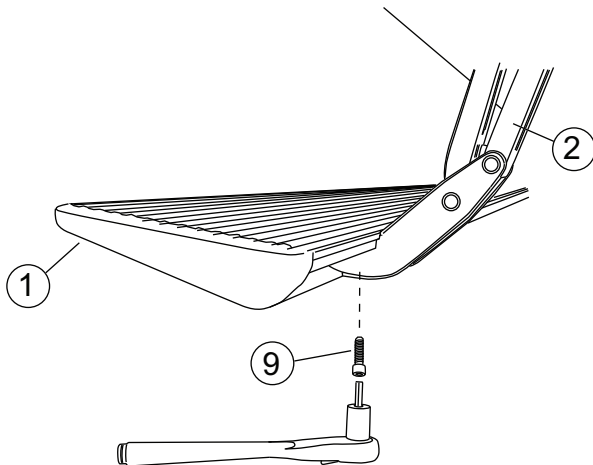

Torque
10 ft-lbs.
(13.5 Nm)

18

19

Route wire harness towards rear of vehicle inside body support gussets. Secure using supplied cable ties. Run wire harness to rear motor assembly and insert plug onto motor.

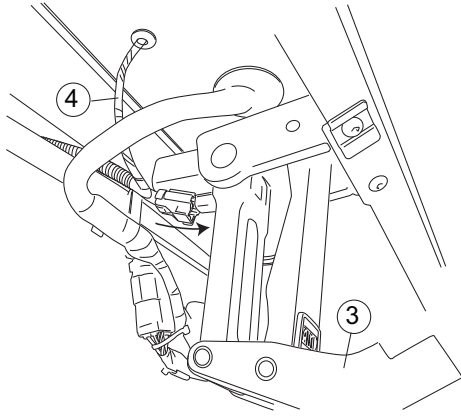

On each side of the vehicle measure from the front edge of door line on the pinch weld to the specified lengths below. Measure at 20" for front LED Light and 60" for rear LED Light.

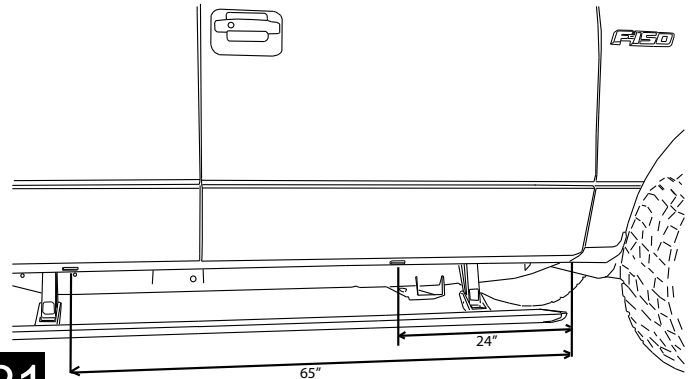

20

21

Affix lamps to rocker panel surface. Make sure the lamp is affixed to a clean, flat surface. There is a step down midway across the surface. Affix lamp just outside of step down.

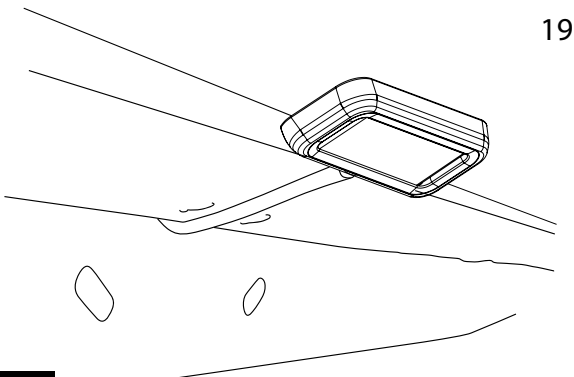

Using supplied butt connectors, connect the lamp wires. Red to Red, Black to Black

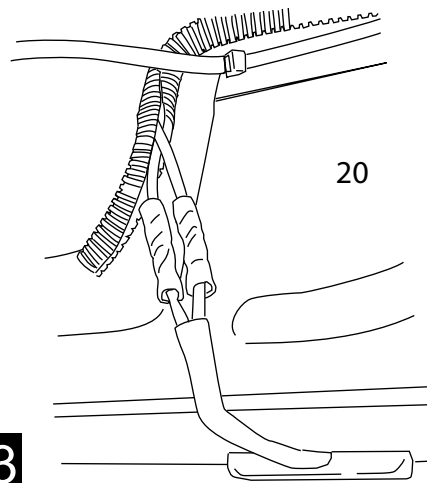

22

23

Close and wrap with conduit and electrical tape. Secure all loose wires with cable ties, with lamp wires pulled upward to avoid any wire snagging.

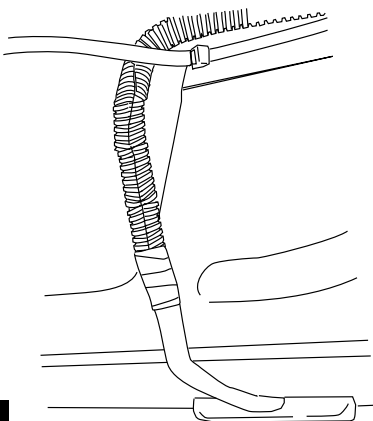

Replace fuse.

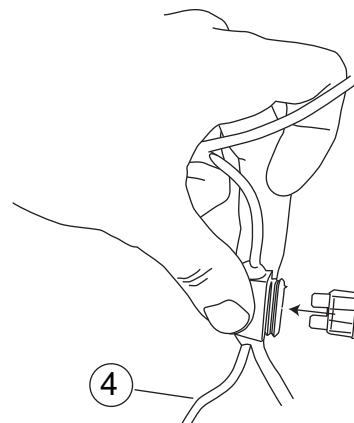

24

25

Check that all doors activate the Power Step and the LED Lights work when doors open and close. Reinstall any remaining trim panels.

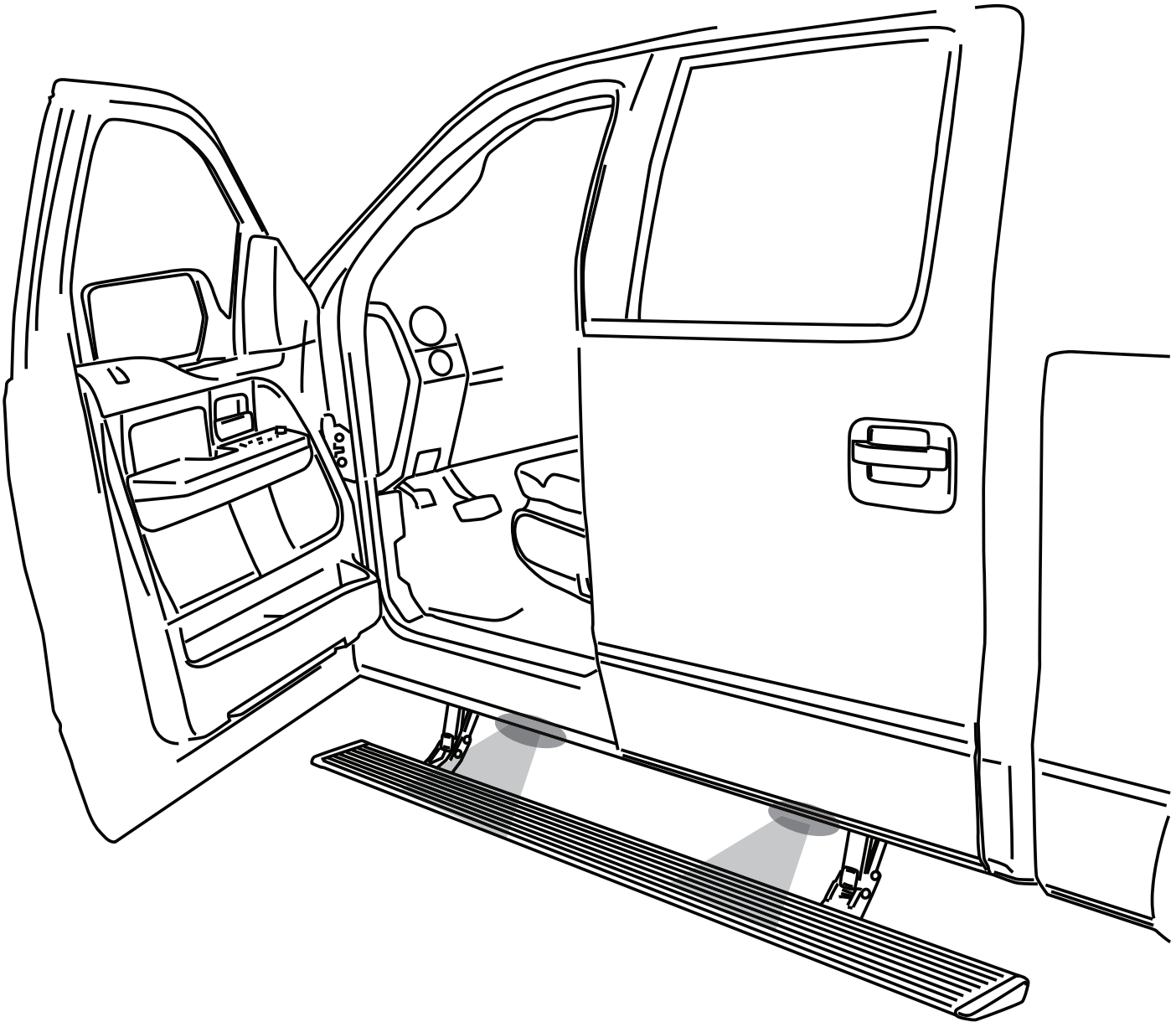

Correct operation of Lights: All four lamps will illuminate upon opening any door of vehicle. Lamps will stay on until restowing of both Power Steps or until 5 minutes has expired with the doors open. When the lights timeout after 5 minutes, they can be reilluminated by closing and opening any door of vehicle.



Congratulations on your purchase of the genuine AMP Research PowerStep! Here's what you should know...



POWERSTEP™ OPERATION - The AMP Research PowerStep™ automatically deploys when any door is opened. When both front and rear doors are closed, it retracts automatically under your vehicle.

The drive system is designed to automatically stop if resistance, blockage or icing occurs. To reset, clear any obstruction, then simply open and close the door and normal operation will resume.

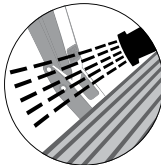

MAINTENANCE TIPS - The stepping surface and linkages should be periodically washed with mild soap and water using a soft brush or sponge to dislodge any mud, dirt or accumulated road grime.

In severe driving conditions, pressure washing the linkages is strongly recommended.

Avoid spraying the motors directly with high-pressure water. After washing, apply Silicone spray lubricant to the pivot pins of each linkage assembly. Remove any excess lubricant with a soft clean cloth. Do not apply Silicone spray, waxes or protectants like Armor All® to the stepping surfaces.



KEEPING POWERSTEP™ DEPLOYED - When washing your vehicle, the PowerStep can be set to remain in the deployed position with the doors closed. **DO THIS...**

1. With the PowerStep deployed, firmly press and hold the step down with your foot.
2. Close the door while continuing to press down on the step. *(This will not harm the motor.)*
3. To resume normal operation, simply open and close the door. *(Repeat for both sides of the vehicle.)*

CAUTION! KEEP HANDS AWAY WHEN THE POWERSTEP IS IN MOTION

AMP RESEARCH LIMITED WARRANTY

AMP RESEARCH warrants this product to be free from defects in material and workmanship for FIVE (5) YEARS FROM DATE OF PURCHASE, provided there has been normal use and proper maintenance. This warranty applies to the original purchaser only. All remedies under this warranty are limited to the repair replacement of the product itself, or the repair or replacement of any component part thereof, found by the factory to be defective within the time period specified. The decision to repair or replace is wholly within the discretion of the manufacturer.

This warranty specifically excludes labor. If you have a warranty claim, first you must call our factory at the number below for instructions. You must retain proof of purchase and submit a copy with any items returned for warranty work. Upon completion of warranty work, if any, we will return the repaired or replaced item or items to you freight prepaid. Damage to our products caused by accidents, fire, vandalism, negligence, misinstallation, misuse, Acts of God, or by defective parts not manufactured by us, is not covered under this warranty.

ANY IMPLIED WARRANTIES OF MERCHANTABILITY AND/OR FITNESS FOR A PARTICULAR PURPOSE CREATED HEREBY ARE LIMITED IN DURATION TO THE SAME DURATION AND SCOPE AS THE EXPRESS WRITTEN WARRANTY. OUR COMPANY SHALL NOT BE LIABLE FOR ANY INCIDENTAL OR CONSEQUENTIAL DAMAGE.

Some states do not allow limitations on how long an implied warranty lasts, or the exclusion or limitation of incidental or consequential damages, so the above limitations or exclusions may not apply to you. This warranty gives you specific legal rights, and you may also have other rights that vary from state to state.

FOR WARRANTY ISSUES WITH THIS PRODUCT PLEASE CALL AMP RESEARCH CUSTOMER SERVICE 1-800-315-9697

WARNING

Be sure to read and precisely follow the provided instructions when installing this product. Failure to do so could place the vehicle occupants in a potentially dangerous situation. After installing or reinstalling, re-check to insure that the product is properly installed.